

Oxygen-Permeable Wine 'Cube' (1,000 L.)

- Replaces four-plus oak barrels at much less cost & 20-plus year life
- Better wine results (no volatiles loss) when quality oak staves are added
- Great oak cost savings. Quality staves cost appr. 10% of barrel based oak in \$/L/year
- Stackable to 4-high, increases cellar capacity 2 to 3 times depending on height & layout
- No topping required, saves 3% to 5% of valuable wine volume per year
- O2 uptake rate same as 2nd to 3rd fill barrels. Thus no special cellaring procedures needed
- Securely transport wine anywhere, including export (20 cubes fit into a 6m FCL)
- Perfect for small-batch fermentations, tippable for lees-stirring & easy solids discharge
- Ullage free shape, hygienic, easy to clean, sterilizable. Full size lid for cleaning access
- Drains freely & completely, the floor slopes to a shallow sump & flangeless floor outlet
- Moulded as a single-piece, seamless unit in special TAINT-FREE wine-grade material

Patented O₂-permeable HDPE vessels. Since 2003, many wine trophies.

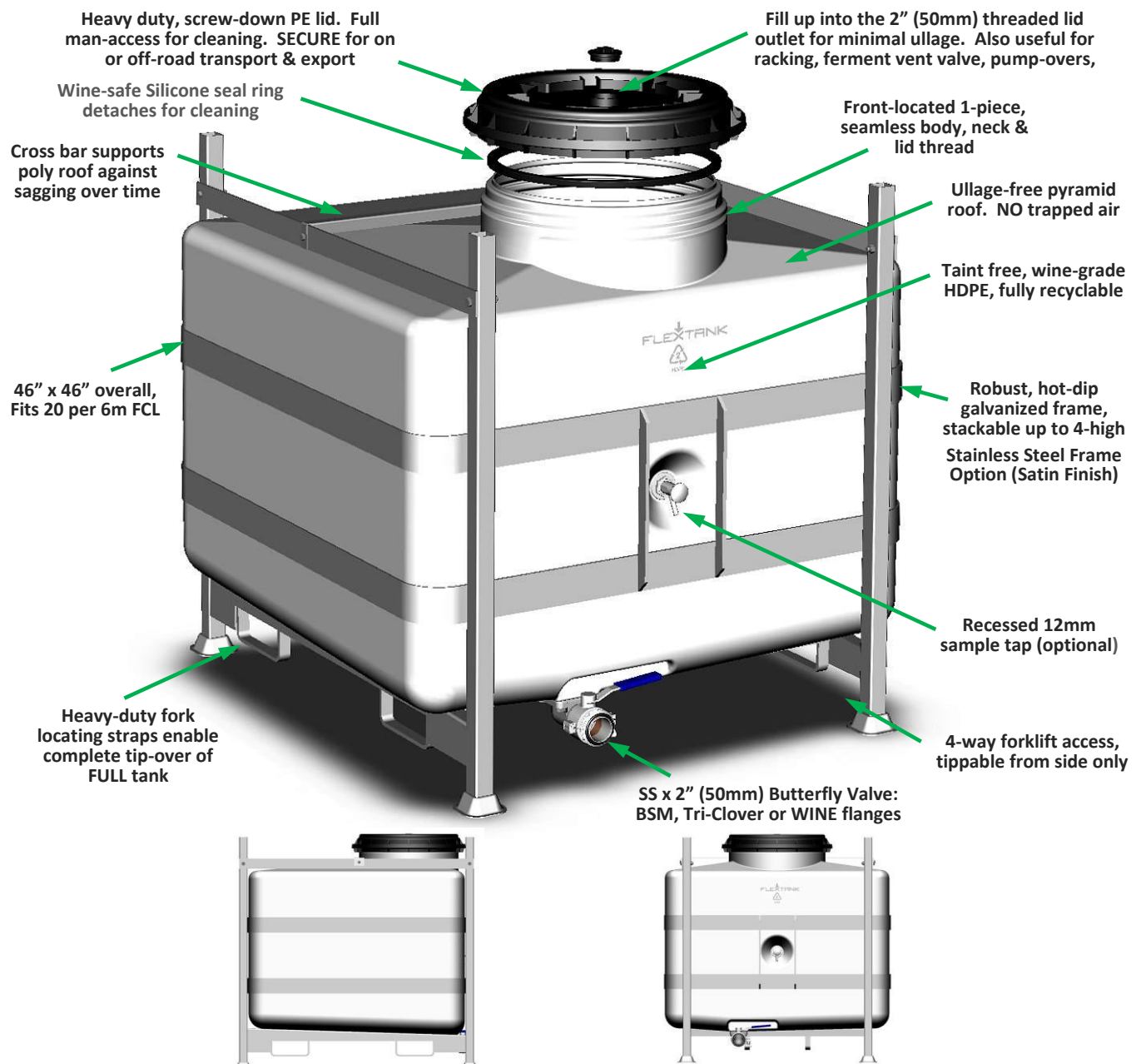

The 2-way sloping floor drains to a bottom-mounted outlet sump and valve, allowing the vessel to drain completely

Dimensions & Performance

Volume: 1,000 litres nominal
 Empty Wgt: ~ 75 kg. incl. frame
 O₂ Uptake: ~ 17 mg per litre per year

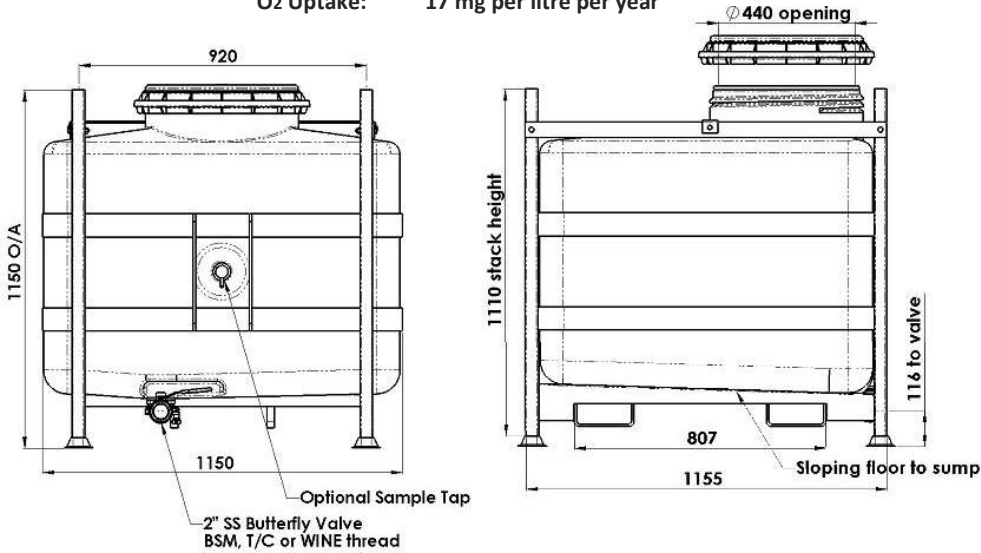

Safe Stackability & Floor Space Saving



Static: 4-high
 Transporting: 2-high

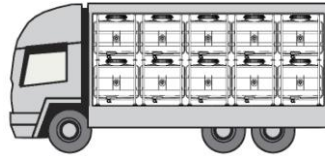

4-stack floor space usage:
 2-3 times less than barrique
 stacks for same stored volume

Working Access when Stacked

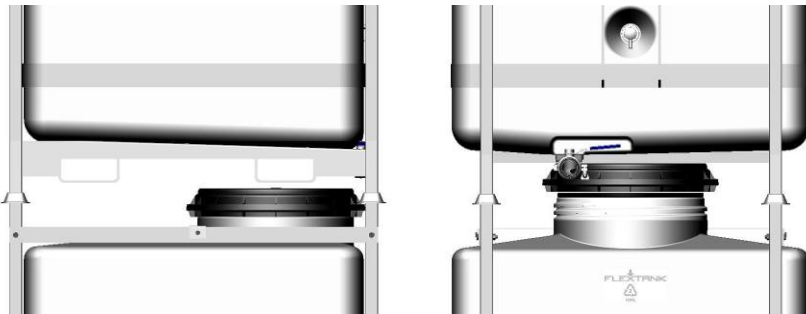

The manhole is located at the front, the valve is offset sidwise & there is sufficient height clearance to remove & replace the lid whilst the tanks are stacked

Options & Accessories

SS sample tap including wall outlet, gasket & nut. Can be retro-fitted



Pallet jackable frame version (i.e. no fork locating straps)



Lid tightening handle, stainless steel, helps ensure a full hermetic seal

Ferment vent option: threaded bush & 1-way tank airlock valve

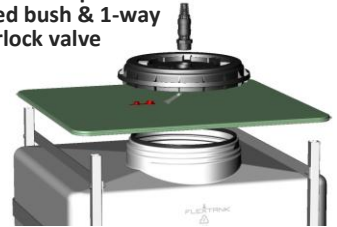

Full-body V-C 'Skin', use for part-fills. Use with CO₂ or N₂ cover



Brushed Stainless Steel Frame Option

High Quality Oak for the finest finished wines

eVOAK
 Forward Thinking Oak Products



OENOSTAVE®
 By SEGUIN MOREAU

Flextank International Limited

1/26 Grosvenor Street, Abbotsford, 3067, Australia
 Ph. +61 3 9428 5842, Fax. +61 3 9428 5862

Peter Steer (BSc.Oen): +61 421 322 779, peter@flextank.com.au
 Geoff Shenfield: +61 438 002 299, geoff@flextank.com.au

flextank
 INNOVATION IN WINEMAKING

www.flextank.com.au